

FLOOR PLAN THI

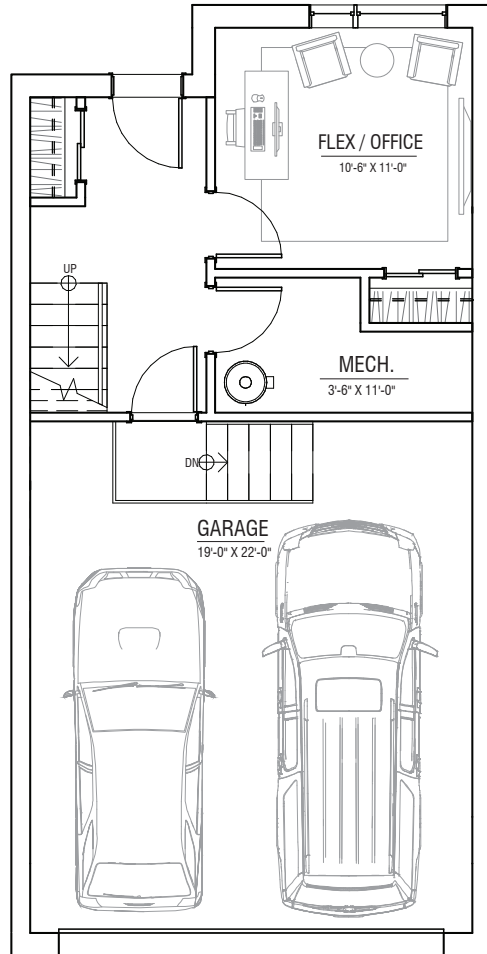

± 1,680 SQ. FT.



LOWER FLOOR
± 280 SQ.FT.

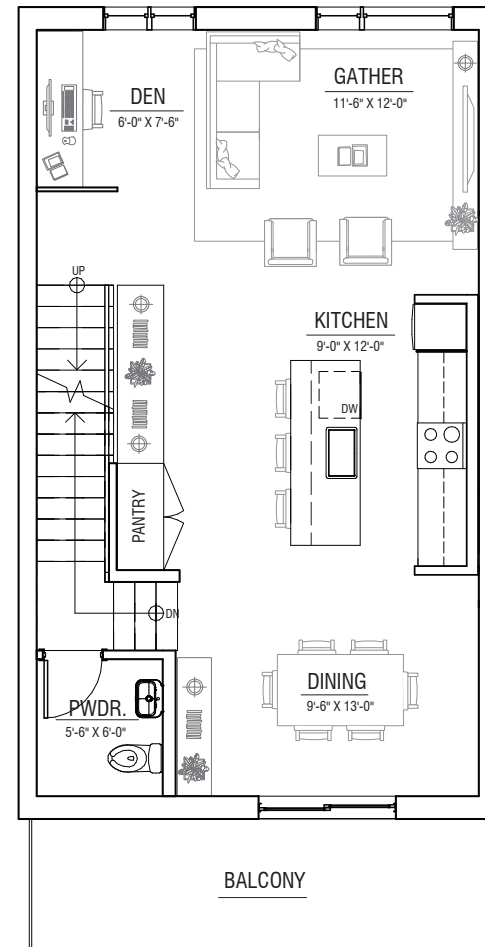

MAIN FLOOR
± 640 SQ.FT.

THE DEVELOPER AND BUILDER RESERVE THE RIGHT TO MAKE MODIFICATIONS AND CHANGES TO THE BUILDING, ANY UNIT, PARKING AREA AND STORAGE AREA DESIGN, SPECIFICATIONS, FEATURES AND FLOOR PLANS IN ORDER TO MAINTAIN THE HIGH STANDARDS OF THIS DEVELOPMENT OR TO COMPLY WITH MUNICIPAL REQUIREMENTS. THE SQUARE FOOTAGE AND ROOM DIMENSIONS ARE BASED ON ARCHITECTURAL DRAWINGS AND MEASUREMENTS. THE LOCATION OF UTILITIES MAY NOT BE ACCURATELY DEPICTED HEREIN. FURNITURE LAYOUTS DEPICT STANDARD FURNISHING SIZES AND ARE INTENDED FOR REFERENCE ONLY. ALL SIZES AND DIMENSIONS ARE APPROXIMATE AND ACTUAL AREA AND DIMENSIONS MAY VARY FROM THE PRELIMINARY PLANS TO THE FINAL SURVEY. E. & O. E.



FLOOR PLAN THI

± 1,680 SQ. FT.

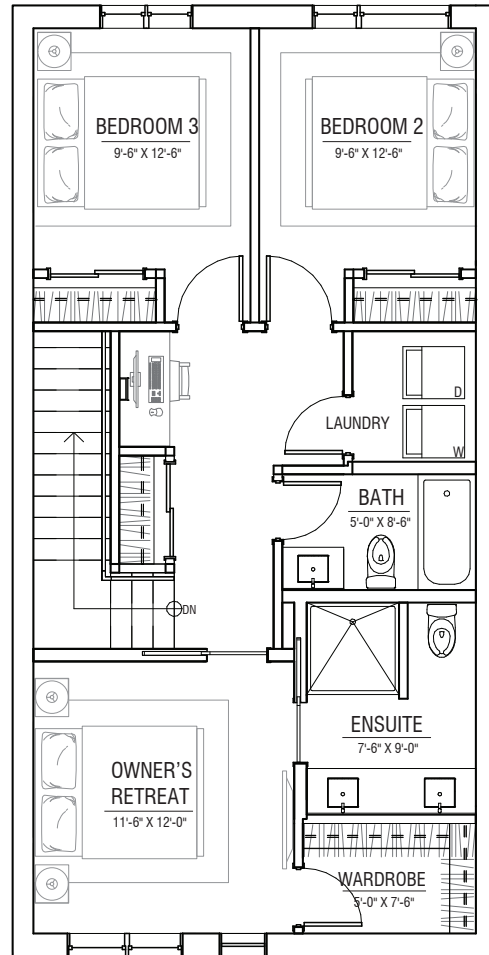

UPPER FLOOR OPTION 1
± 760 SQ.FT.

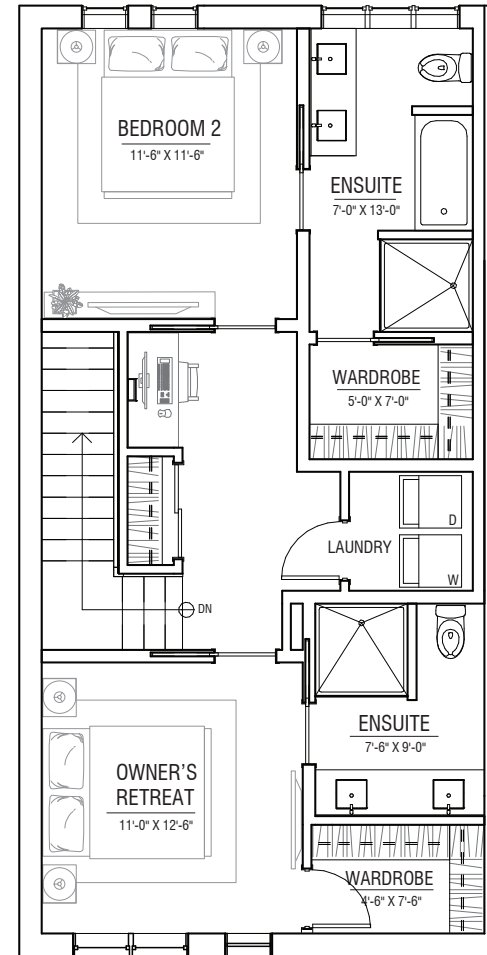

UPPER FLOOR OPTION 2
± 760 SQ.FT.

FLOOR PLAN TH2

± 1,680 SQ. FT.

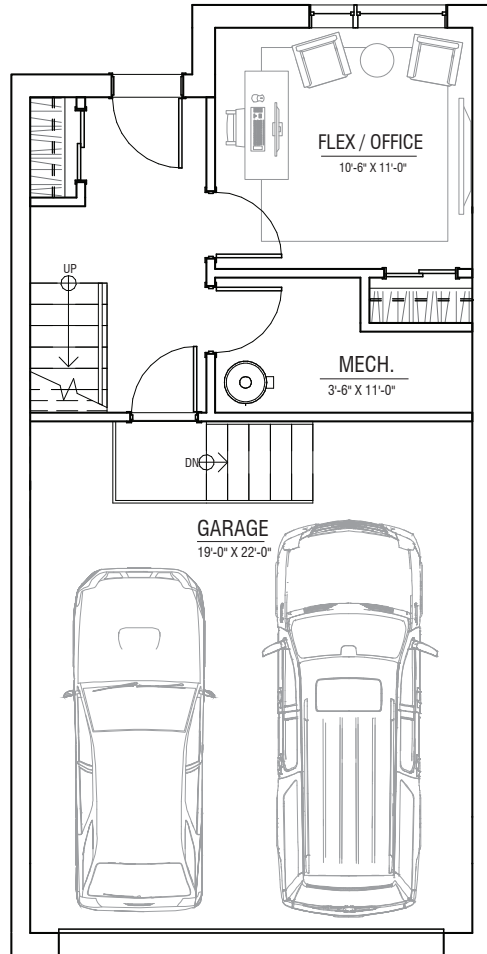

LOWER FLOOR
± 280 SQ.FT.

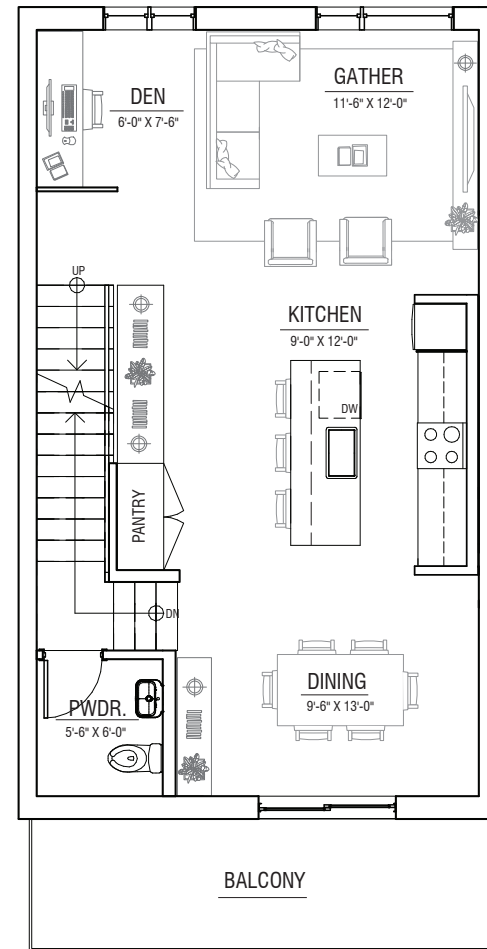

MAIN FLOOR
± 640 SQ.FT.

THE DEVELOPER AND BUILDER RESERVE THE RIGHT TO MAKE MODIFICATIONS AND CHANGES TO THE BUILDING, ANY UNIT, PARKING AREA AND STORAGE AREA DESIGN, SPECIFICATIONS, FEATURES AND FLOOR PLANS IN ORDER TO MAINTAIN THE HIGH STANDARDS OF THIS DEVELOPMENT OR TO COMPLY WITH MUNICIPAL REQUIREMENTS. THE SQUARE FOOTAGE AND ROOM DIMENSIONS ARE BASED ON ARCHITECTURAL DRAWINGS AND MEASUREMENTS. THE LOCATION OF UTILITIES MAY NOT BE ACCURATELY DEPICTED HEREIN. FURNITURE LAYOUTS DEPICT STANDARD FURNISHING SIZES AND ARE INTENDED FOR REFERENCE ONLY. ALL SIZES AND DIMENSIONS ARE APPROXIMATE AND ACTUAL AREA AND DIMENSIONS MAY VARY FROM THE PRELIMINARY PLANS TO THE FINAL SURVEY. E. & O. E.

FLOOR PLAN TH2



± 1,680 SQ. FT.

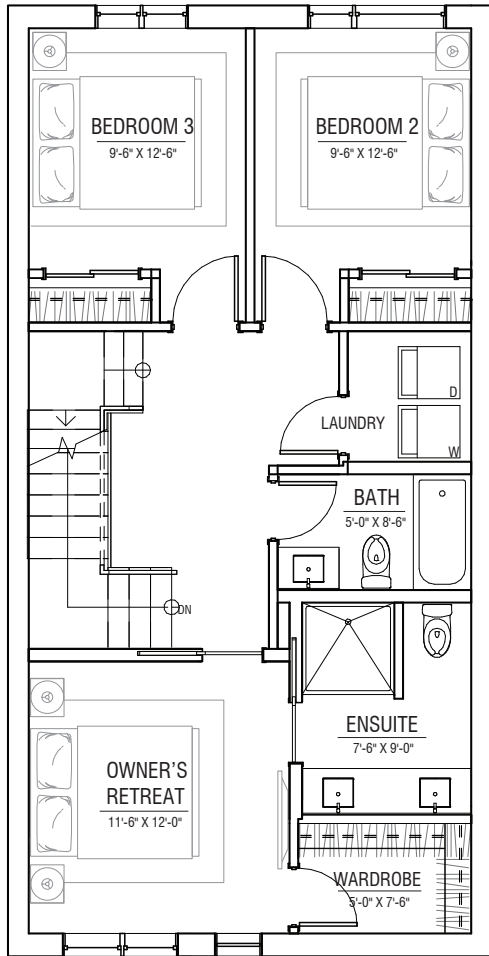

UPPER FLOOR OPTION 1
± 760 SQ.FT.

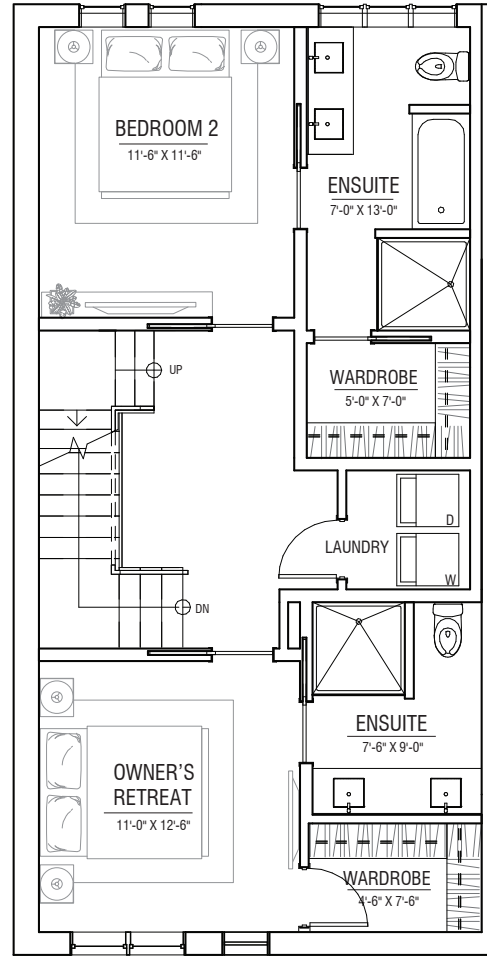

UPPER FLOOR OPTION 2
± 760 SQ.FT.

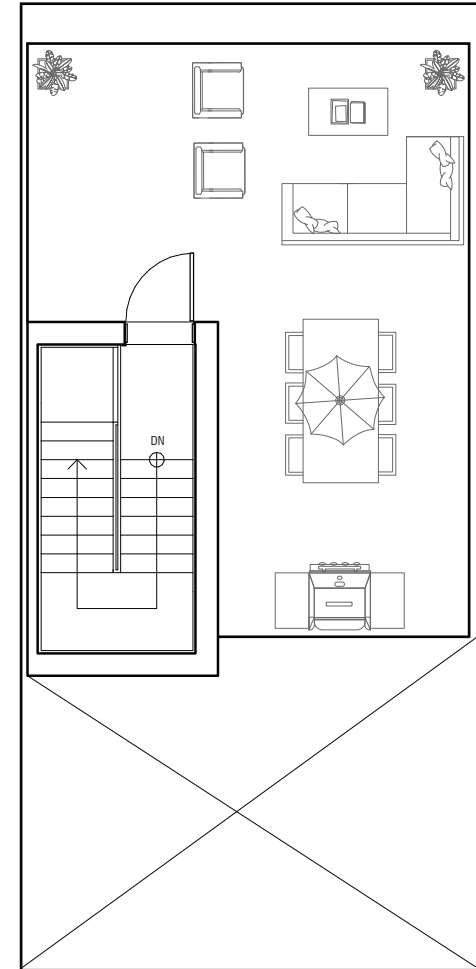

ROOFTOP PATIO
± 390 SQ.FT.

THE DEVELOPER AND PURCHASER RESERVE THE RIGHT TO MAKE MODIFICATIONS AND CHANGES TO THE BUILDING, ANY UNIT, PARKING AREA AND STORAGE AREA DESIGN, SPECIFICATIONS, FEATURES AND FLOOR PLANS IN ORDER TO MAINTAIN THE HIGH STANDARDS OF THIS DEVELOPMENT OR TO COMPLY WITH MUNICIPAL REQUIREMENTS. THE SQUARE FOOTAGE AND ROOM DIMENSIONS ARE BASED ON ARCHITECTURAL DRAWINGS AND MEASUREMENTS. THE LOCATION OF UTILITIES MAY NOT BE ACCURATELY DEPICTED HEREIN. FURNITURE LAYOUTS DEPICT STANDARD FURNISHING SIZES AND ARE INTENDED FOR REFERENCE ONLY. ALL SIZES AND DIMENSIONS ARE APPROXIMATE AND ACTUAL AREA AND DIMENSIONS MAY VARY FROM THE PRELIMINARY PLANS TO THE FINAL SURVEY. E. & O. E.





THE BUILDINGS

- Built by Truman - Customer Choice Award Winner for highest Customer Satisfaction
- Comprehensive coverage including deposit payments protected by Alberta New Home Warranty Program
- Clad in brick and James Hardie siding, these homes feature maintenance free exteriors highlighting large private balconies
- Approximate ±9 foot main floor ceilings
- Luscious, professionally designed and irrigated landscaped areas throughout site
- Peace of mind provided through our comprehensive warranty program: 1 Year on Workmanship & Materials, 2 Year Warranty of Delivery & Distribution Systems, 5 Year Building Envelope Coverage, and 10 Year Structural Warranty
- Knockdown ceilings throughout finished areas

THE HOMES

District Townhomes at West District are elegant residences created and curated by Truman's award-winning interior design team, highlighted by the following finishes:

Fresh Flooring

- Selection of high quality wide plank laminate flooring with acoustic underlay throughout main living areas (excluding tile areas & stairs, upper floor optional)
- Plush high grade patterned carpet on stairs & upper floors
- Custom full height tile kitchen backsplashes (optional upgrade to full height quartz backsplash)

Windows & Doors

- Custom designed entry door accented by individual custom lighting fixture
- High quality aluminum clad windows and clear thermal glazing on operating screened-windows



Meticulous Millwork

- Smooth panel doors with anti-scuff and scratch Taymor hardware
- Modern 3" profile painted baseboards
- Modern 3" profile painted door frames and casings
- Ample Glide Free® closet storage shelving (as per plan)
- Master walk-in closet cabinet featuring textured medina cabinet tower
- Painted railings with modern metal spindles

Brilliant Lighting

- 6 LED pot lights throughout main floor
- Hand-picked contemporary & energy efficient interior light fixtures

THE KITCHENS

- Award winning floor to ceiling ergonomic TRUspace® cabinets featuring premium zero-edge finishes, available in Blanc or Noir colour palettes
- Polished quartz hard surface eased-edge countertops
- Undermount sink with industrial high arc single lever faucet
- Full height tile kitchen backsplashes
- Energy saving under-cabinet LED lighting
- Custom made cabinet door hardware (as per selections)
- Soft-close door & drawer technology with integrated storage featuring cutlery drawer, deep pot/pan drawers and built-in bakeware organizer in cabinetry above fridge



THE APPLIANCES

- Panelled Fisher & Paykel 36" built-in French door refrigerator with ice maker in freezer (non-dispensing), glass shelves and Active Smart system
- Whirlpool 1.6 cubic ft. microwave with 27" trim kit
- 600 CFM above range hood fan
- Whirlpool stainless steel gas range featuring 4 sealed gas burners, self-cleaning 5.0 cubic ft. oven and cast iron full-width satin finish grates
- Whirlpool 24" fingerprint resistant stainless steel built-in dishwasher featuring adjustable upper rack & sensor cycle
- Ultra-quiet in-suite Energy Star® front load stacked washer and dryer with quick water shut off valve





THE BATHROOMS

- Convenient two-piece powder room alongside main living area
- Eased edge polished quartz countertops (as per plan)
- Modern square edge tub with sloping lumbar support and upgraded contemporary tiles inspire a luxe spa atmosphere
- Chrome plumbing fixtures with undermount porcelain vessel sink
- Porcelain comfort-height toilets
- Matching Taymor hardware and accessories
- Polished edge glass shower door and frame (as per plan, ensuite only, where applicable)
- Environmentally conscious Water Sense® fixtures and toilets
- Safety and pressure-balancing mixing valves for tub and showers

THE MECHANICS

- Forced-air high efficiency gas furnace with drip humidifier and high efficiency hot water tank (electric)
- Roughed-in for security, VACUFLO system, and home networking (low voltage cabling to smart panel)
- Programmable thermostat and power HRV (heat recovery ventilator)
- Smart technology featuring integrated wiring to panel, smart plug USB jack, TV and telephone connections in principal areas